

# СИ30

Pulse counter



User manual

# Contents

<b>Introduction</b> .....	<b>4</b>
<b>Safety instructions</b> .....	<b>6</b>
<b>1 Purpose and functions</b> .....	<b>7</b>
<b>2 Specifications and operating conditions</b> .....	<b>7</b>
2.1 Specifications .....	7
2.2 Operating conditions .....	9
<b>3 Safety measures</b> .....	<b>10</b>
<b>4 Mounting</b> .....	<b>11</b>
4.1 Installation of device in housing H .....	11
4.2 Installation of device in housing $\sqcup$ 1 .....	13
4.3 Installation of device in housing $\sqcup$ 2 .....	16
<b>5 Electrical connections</b> .....	<b>18</b>
5.1 Wiring recommendations .....	18
5.2 Getting Started.....	19
5.3 Pin assignment .....	20
5.4 Connection of switching devices and sensors.....	21
5.5 Connecting load to the outputs.....	26
<b>6 Operation of the device</b> .....	<b>29</b>
6.1 Principle of operation.....	29
6.2 Control and indication.....	31
6.3 Switch on and operation .....	35
<b>7 Setup</b> .....	<b>36</b>
7.1 Sequence of setup .....	36

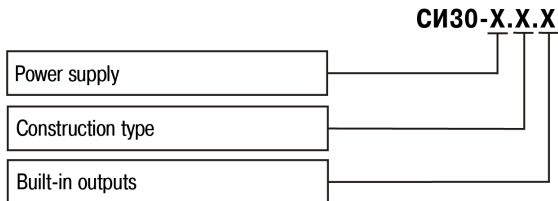
7.2 Setting the operating mode of the counter .....	42
7.3 Configuring the device from PC .....	53
<b>8 Maintenance .....</b>	<b>53</b>
<b>9 Marking .....</b>	<b>53</b>
<b>10 Packaging .....</b>	<b>54</b>
<b>11 Transportation and storage .....</b>	<b>54</b>
<b>12 Scope of delivery .....</b>	<b>55</b>
<b>13 Warranty .....</b>	<b>55</b>
<b>Appendix A Device parameters .....</b>	<b>57</b>

# Introduction

This user manual is intended to familiarize service personnel with the design, principle of operation, structure, operation and maintenance of the pulse counter **СМ30** (further in the text called «device»).

Connection, setup and maintenance should be made only by qualified specialists after reading this manual.

The device is produced in various modifications, that are encrypted in code of full conventional designation.



## Power supply:

**220** – 90...250 V AC, 50 Hz;

**24** – 10,5...30 V DC.

## Construction type:

**H** – wall-mounting housing;

**Щ1** – panel-mounting housing (square front panel, 96x96 mm);

**Щ2** – panel-mounting housing (rectangular front panel, 96x48 mm).

**Built-in outputs:**

**P** – electromagnetic relay;

**K** – transistor optocoupler of *n-p-n* type;

**C** – triac optocoupler.

The example of designation used for ordering and in other products documentation:

Pulse counter **СИ30-220.Щ2.Р ТУ 4278-007-46526536-2010**.

## Safety instructions

Following symbols and keywords are used in this manual:



### **DANGER**

Keyword DANGER is used to warn about an imminent threat to health. Possible consequences may include death, permanent or prolonged incapacity for work.



### **NOTICE**

Keyword CAUTION is used to prevent a potentially dangerous situation. Possible consequences may include minor injuries.



### **CAUTION**

Keyword WARNING is used to warn about damage to property and devices. Possible consequences may include damage to property, for example, this device or connected devices.



### **NOTE**

Keyword NOTICE is used for supplement, clarifying, interpretation of the main text and/or clarifying specific aspects of working the device operation.

# 1 Purpose and functions

The device is a universal counter that can be used for a wide range of automation tasks. It is designed to count the number of pulses coming to its inputs in direct and opposite direction and to convert further this number into a physical value (using multiplication by given multiplier).

The device can perform following functions:

- count-up, count-down, reversing and other types of counting pulses from the connected sensors;
- determination of the direction of rotational motion of units and mechanisms;
- converting the number of pulses into real units of measurement;
- powering sensors from the built-in 24 V DC power source;
- load control by two built-in outputs;
- saving counting results when power is turned off;
- connection to PC via embedded RS-485 and USB interfaces.

## 2 Specifications and operating conditions

### 2.1 Specifications

Main specification of the device is given in *Table 2.1*.

**Table 2.1 – Device features**

Item	Value
<b>Power supply</b>	
AC: <ul style="list-style-type: none"><li>• supply voltage</li><li>• frequency</li></ul>	90...250 V (nominal - 110, 220 or 240 V) 47...63 Hz (nominal - 50 and 60 Hz)

**Table 2.1 (continued)**

<b>Item</b>	<b>Value</b>
DC	10.5...30 V
Power consumption, max.	12.5 VA
<b>Inputs</b>	
Number of control inputs	4
Logical 0	0...4 V
Logical 1	10...30 V
Current for sensor's polling	2 mA
Nominal supply voltage of the sensors	24 V
Instability of sensor supply voltage	10 %
Load current for power supply of sensors, max.	100 mA
<b>Outputs</b>	
Number of outputs	2
Current switched by relay contacts, max.	8 A (220 V AC, $\cos \varphi > 0.4$ )
Current of transistor optocoupler load, max.	0.2 A (at 50 V)
Current of optotriac load, max.: - at 240 V (constantly open triac) - if the triac is switched on with frequency = 50 Hz max and $t_{imp} = 5$ ms	50 mA 0.5 A
<b>Pulse counter</b>	
Number of display digits	6
Counting speed, max.	10 000 Hz
Duration of input pulses, min.	50 $\mu$ s



**Table 2.1 (continued)**

<b>Item</b>	<b>Value</b>
Range of values of the multiplier	from 0.00001 to 99999
Frequency of input filter	from 1 to 50000 Hz
Pulse ratio, min.	2
Limit of permissible basic error (according to GOST 24907)	±1 junior digit
Basic reduced error for measurement of time intervals	±1% from 0.1 to 999.99 ctr
<b>Housing</b>	
Dimensions: • wall-mounting H • panel-mounting Щ1 • panel-mounting Щ2	105x130x65 mm 96x96x70 mm 96x48x100 mm
Protection class: • wall-mounting H • panel-mounting Щ1 and Щ2	IP44 IP54 (front panel side)
<b>Device features</b>	
Weight, max.	1 kg
Average service life	8 years
Calibration interval	2 years

## 2.2 Operating conditions

The device must be used in following conditions:

- closed explosion-proof areas without aggressive vapors and gases;

- ambient temperature from -20 to +70 °C;
- upper limit of relative humidity = max. 95% at 35°C and lower temperatures without moisture condensation;
- atmospheric pressure from 84 to 106.7 kPa.

In terms of resistance to mechanical influences during operation the device corresponds to group of performance N2 in GOST R 52931-2008.

**NOTICE**

It is necessary to comply with the requirements for operating conditions, as they are part of safety measures.

### 3 Safety measures

**CAUTION**

The terminal block has life-threatening voltage up to 250 V. Any connections to the device and maintenance work should be carried out only when the power is turned off.

By the method of protection from electric shock the device corresponds to class II according to GOST 12.2.007.0-75.

While operating, maintaining and checking, it is necessary to comply with GOST 12.3.019-80, Rules of the technical operation of electrical consumers and Safety rules for operating electrical equipment.

There must be no moisture on the output terminals and the internal components of the device. It is forbidden to use the device in corrosive environments with acids, alkalis, oils, etc. in the air.

## 4 Mounting

### 4.1 Installation of device in housing H

For installation of the device perform following actions:

1. Fasten the bracket on the surface intended for mounting with three M4 × 20 screws (see *Figure 4.2*).



#### NOTICE

Screws for bracket are not included in the package.

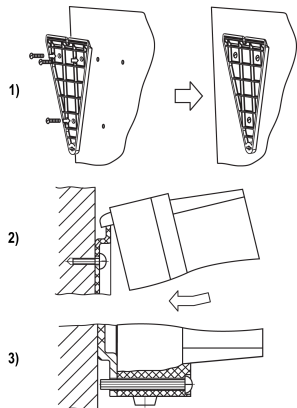
2. Hook the fixing bracket from the back panel of device to the upper edge of the wall bracket.
3. Attach device to the bracket with the supplied screw.

Demount the device in the reverse order.

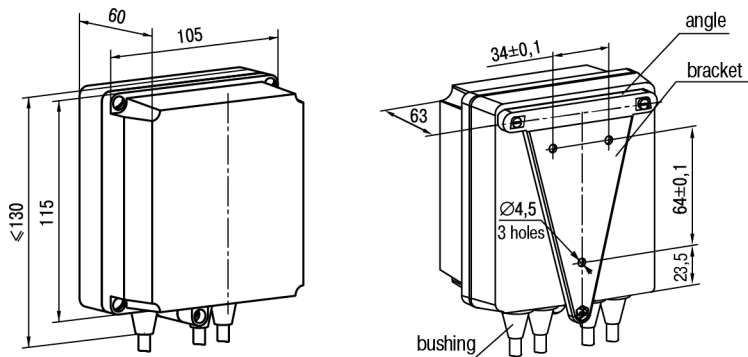


#### NOTICE

Remove the cover before wiring. Fasten the base of the device to the bracket with a supplied screw.



**Figure 4.1 – Installation of wall-mounting device**



**Figure 4.2 – Dimensions of H housing**



**NOTICE**

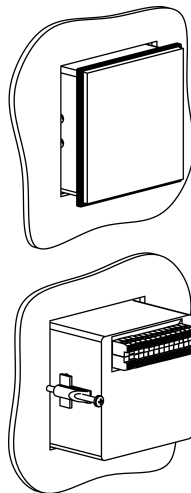
The bushings need to be cut in accordance with the diameter of the lead-in cable.

## 4.2 Installation of device in housing Щ1

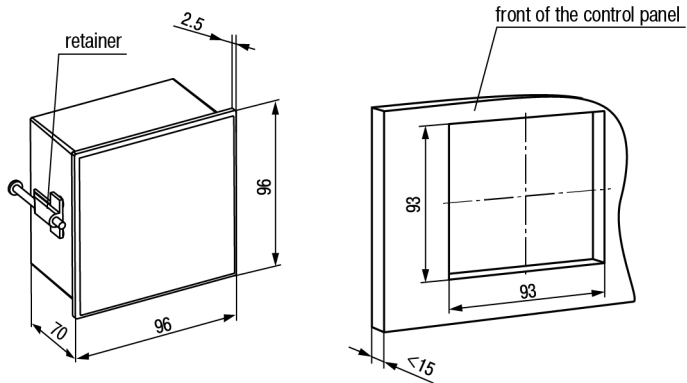
For installation of the device perform following actions:

1. Prepare a place for mounting on the control panel (see *Figure 4.4*).
2. Install the gasket on the frame of the device to ensure degree of protection IP54.
3. Insert the device into a specially prepared hole on the front of the control panel.
4. Insert the supplied retainers into holes on the sides of the device.
5. Tighten supplied screws M4 x 35 in the holes of each retainer so that the device is pressed firmly to the front of the control panel.

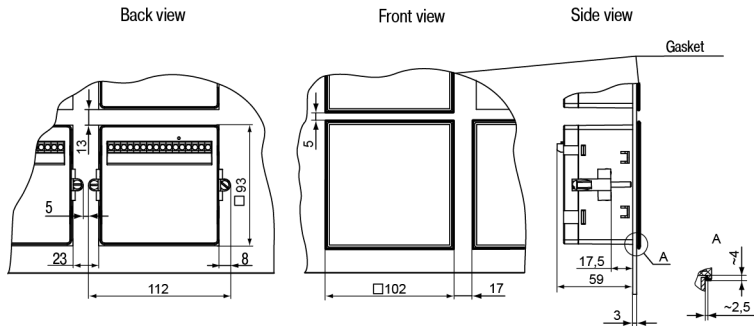
Demount the device in the reverse order.



**Figure 4.3 – Installation of panel-mounting device**



**Figure 4.4 – Dimensions of Ц1 housing**



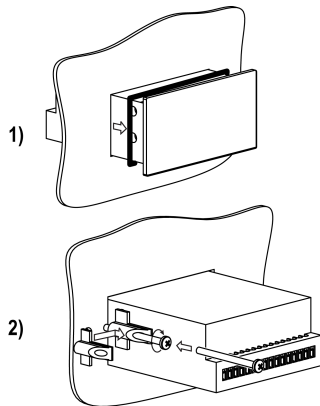
**Figure 4.5 – Device in Щ1 housing mounted in the control panel with 3 mm thickness**

### 4.3 Installation of device in housing Щ2

For installation of the device perform following actions:

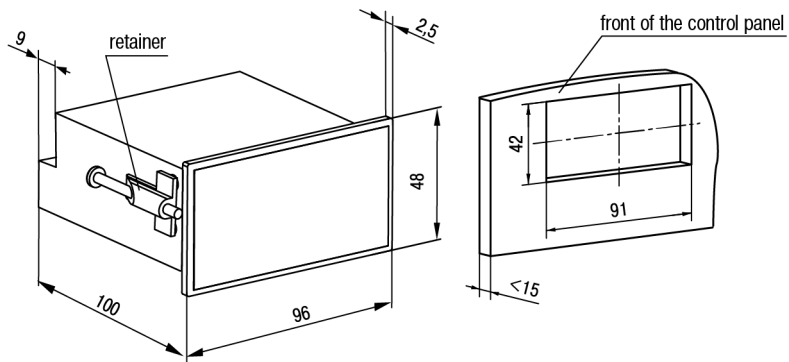
1. Prepare a place for mounting on the control panel (see *Figure 4.8*).
2. Install the gasket on the frame of the device to ensure degree of protection IP54.
3. Insert the device into a specially prepared hole on the front of the control panel.
4. Insert the supplied retainers into holes on the sides of the device.
5. Tighten supplied screws M4 x 35 in the holes of each retainer so that the device is pressed firmly to the front of the control panel.

Disassemble the device in the reverse order.

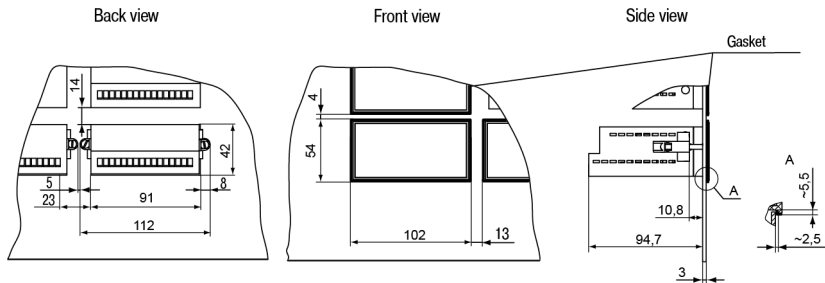


**Figure 4.6 – Installation of panel-mounting device**





**Figure 4.7 – Dimensions of  $\sqcup 2$  housing**



**Figure 4.8 – Device in  $\square 2$  housing mounted in the control panel with 3 mm thickness**

## 5 Electrical connections

### 5.1 Wiring recommendations

To ensure the reliability of electrical connections it is recommended to use copper multicore cables, the ends of which should be carefully cleaned, tinned, otherwise use cable lugs before connection. Stripping of conductors must be performed in such way that the stripped ends after connecting to the device do not protrude beyond the terminal block. Cable cross section should be no more than 1 mm<sup>2</sup>.

General requirements for connection lines:

- During the cabling, communication lines that connect the device with sensors must be isolated to a separate circuit (or several circuits) and placed separately from power cables or other sources of high-frequency and impulse interferences.

- To protect the device inputs from the effects of industrial electromagnetic interference, the communication lines between device and sensors should be screened. Special cables with shielding or grounded steel pipes of suitable diameter can be used as screens. The cable shielding should be connected to the functional ground terminal (FE) in the control panel.
- Network interference filters should be installed in the power supply lines.
- It is necessary to install spark-suppression filters in the lines of switching of power equipment.

When mounting the system in which the device is used, the rules for effective grounding should be taken into account:

- all grounding lines must be laid in Y-connected circuit, ensuring good contact with the grounding element;
- all earthing circuits must be made with wires of the largest possible cross-section;
- it is forbidden to connect the device terminal "Common" with grounding lines.

## 5.2 Getting Started



### **DANGER**

After unpacking the device, make sure that it has not been damaged during transportation.

If the device has been for a long time at a temperature below minus 20 °C, it is necessary to keep it in a room with a temperature corresponding to the operating range for at least 30 minutes before switching on and operation.

For connecting the device perform following actions:

1. Connect the device to a power source.

**CAUTION**

Before powering up the device, it is necessary to check the correct connection of the supply voltage and its level.

2. Connect the "device - sensors" communication lines to the sensors and to device inputs.
3. Connect the "device - load" communication lines to the actuators and to outputs of the device.
4. Apply power to the device.
5. Set up the device.
6. Power off the device.

### 5.3 Pin assignment

Screw terminals are located on the back wall of the panel-mounting device or inside the device (wall-mounting). The terminal block contacts assignment is shown in *Figure 5.1*.

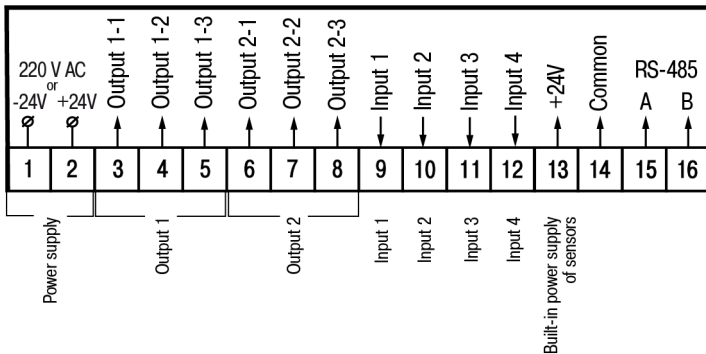


Figure 5.1 – Terminal block contacts assignments

## 5.4 Connection of switching devices and sensors



### CAUTION

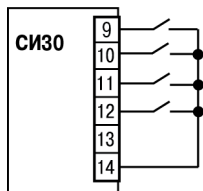
Supply voltage on the device inputs (pins 9 – 12 at the terminal block) must be in range from 0 to 24 V.



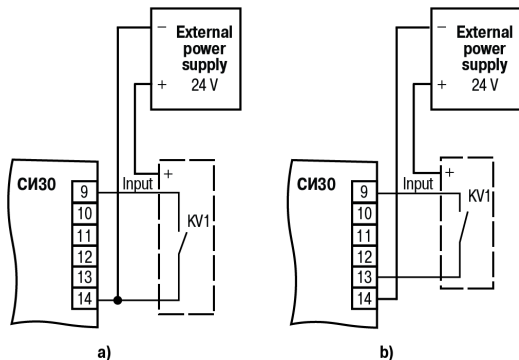
### NOTICE

To supply the switching devices and sensors to the screw terminal block of the device is provided with supply voltage (pin 13 of the terminal block). If power consumption of input exceeds the load capacity of the built-in power supply (24 V), then an external power supply with an output voltage of 12 to 34 V (24 V recommended) must be used for powering.

Scheme for connection of the switching devices to the inputs is shown in *Figures 5.2 and 5.3* .

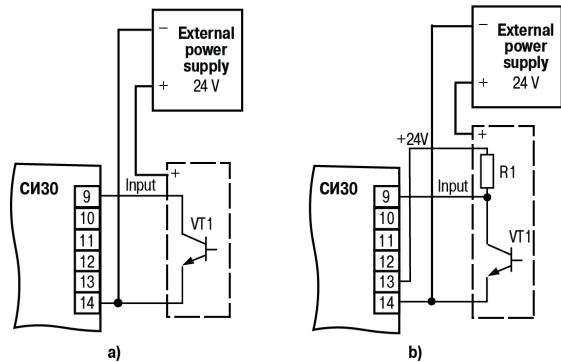


**Figure 5.2 – Connection of "dry contact" switching devices**



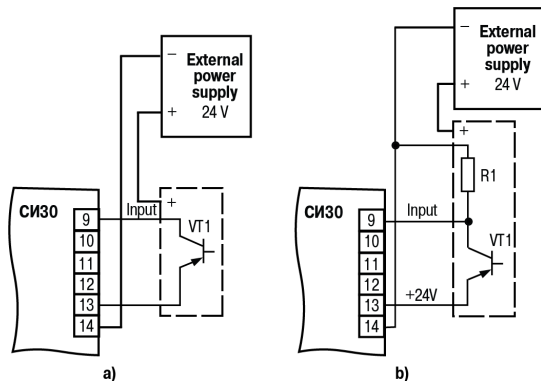
**Figure 5.3 – Connection of switching devices: a) for operation with  $n-p-n$  sensors; b) for operation with  $p-n-p$  sensors**

Scheme for connection of passive and active sensors with an output  $n-p-n$  open-collector transistor or  $p-n-p$  is shown in *Figures 5.4 and 5.5* accordingly.



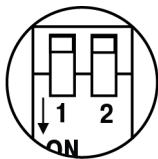
**Figure 5.4 – Connection of n-p-n-sensors: a) active; b) passive**





**Figure 5.5 – Connection of p-n-p-sensors: a) active; b) passive**

Device has a dual switch for selecting, which of the types of sensors will work. It is located on the lateral side of the housing Ц1 and Ц2. For device in the H housing, the switch is located inside the housing (to access the switch, it is necessary to remove the device cover by unscrewing the four screws that fasten the cover to the base). Appearance of the switch is shown in *Figure 5.6*.



**Figure 5.6 – Dual switch**

Positions of the switch depending on which device operates with different sensors, are shown in *Table 5.1*.

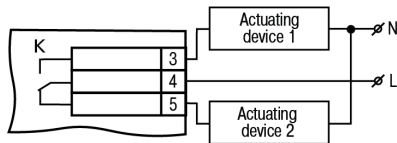
**Table 5.1 – Switch status for different types of sensors**

Type of sensors	Switch positions
<i>n-p-n</i>	1 – OFF↑; 2 – ON↓
<i>p-n-p</i>	1 – ON↓; 2 – OFF↑

## 5.5 Connecting load to the outputs

Outputs can be made in the form of electromagnetic relays (P), transistor (K) or triac (C) optocouplers. The outputs are used for direct load control (on/off) or for control by more powerful elements: contactors, solid state relays, thyristors or triacs. The outputs are galvanically isolated from the circuit of the device.

Scheme of connecting the load to the electromagnetic relay is shown in *Figure 5.7*.



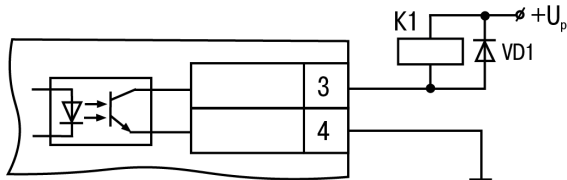
**Figure 5.7 – Scheme of connecting load to the output of type P**

A transistor optocoupler is usually used to control a low-voltage relay (up to 50 V) – see *Figure 5.8*.



**CAUTION**

The diode VD1 (KD103 or similar type) should be installed in parallel to the relay coil, in order to avoid failure of the transistor due to the large self-induction current.

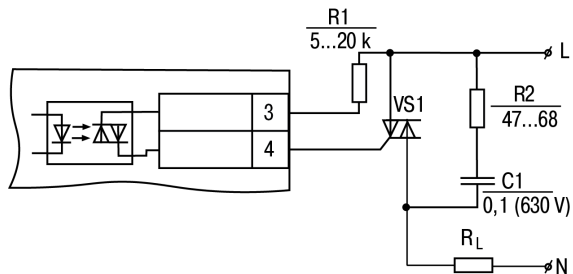


**Figure 5.8 – Scheme of connecting load to the output of type K**

The optosimistor is connected to the control circuit of the power triac through the limiting resistor R1 according to the scheme shown in *Figure 5.9*.

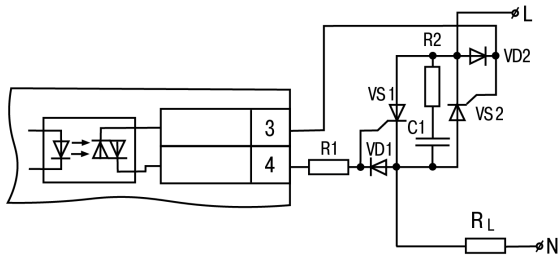
**NOTICE**

Nominal value of the resistor determines the current of the triac.



**Figure 5.9 – Scheme of connecting a power triac to the output of type C**

Optosimistor can also control a pair of anti-parallel connected thyristors (see *Figure 5.10*).



**Figure 5.10 – Scheme of connecting two anti-parallel connected thyristors to the output of type C**



**CAUTION**

It is recommended to connect a filtering circuit (RC) to the terminals of thyristors or triacs in order to prevent breakdown due to high-voltage power surges in the network.

## 6 Operation of the device

### 6.1 Principle of operation

Functional diagram of the device is shown in *Figure 6.1*.

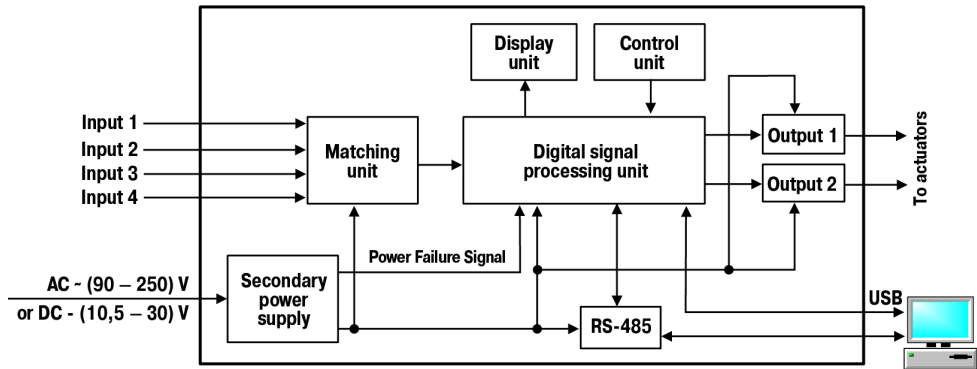


Figure 6.1 – Functional diagram

The device has four independent digital *inputs* for external control signals. To *the inputs* can be connected:

- switching devices (buttons, switches, reed switches, relays, etc.);
- sensors with output *n-p-n*-transistor with an open collector;
- sensors with output *p-n-p*-transistor.

The levels of the input signals are converted and processed in *the matching unit* and then sent to *the digital signal processing unit* that performs:

- reassignment of inputs in accordance with the selected counting mode (see *section 7.2*);

- filtering of input signals (see *section 6.3*);
- counting incoming pulses on the device inputs;
- conversion of the value from the counter into real physical value;
- comparing signal value to the setpoint before displaying;
- generation of signals for controlling the **outputs** according to a specified algorithm.

**Control unit** includes buttons for entering parameters of the device.

**Display unit** displays the measurement results or operating parameters on the indicators and shows the counter status using LEDs.

**Secondary power supply** converts the incoming voltage for all units of the device, depending on the version (with AC or DC power supply), and generates a signal indicating the loss of supply voltage.

The device can be connected with PC using **RS-485** and **USB** interfaces that allow to set and edit the device configuration, monitor its current status and indications.

## 6.2 Control and indication

Elements of indication and control are located on the front panel of the device (see *Figures 6.2 and 6.3*):

- two seven-segment six-digit digital indicators, red and green – see *Table 6.1*;
- six/eight LEDs (depending on the construction type) – see *Table 6.2*;
- four/five buttons (depending on the construction type) – see *Table 6.3*.

All elements are placed on two (in housings  $\sqcup 1$  and H) or on three printed circuit boards (in housing  $\sqcup 2$ ).



Figure 6.2 – Front panel of the device in housings for wall-mounting H and panel-mounting Щ1

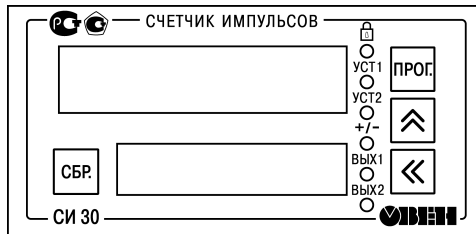



Figure 6.3 – Front panel of the device in housing for panel-mounting Щ2



**Table 6.1 – Assignment of digital indicators**

Indicator	Operating mode of the device	Displayed information
Upper indicator (red)	Operation	Current counter value
	Setup	Name of the selected parameter
Lower indicator (green)	Operation	Setpoint value
	Setup	Parameter value

**Table 6.2 – LEDs assignment**

LED	Status	Description
	lights	Key lock is on
УСТ1 УСТ2	lights	Number of setpoint (1 or 2) that is currently displayed on the lower indicator
+/-	lights	Direct counting
	extinguished (off)	Reverse counting
ВЫХ1 ВЫХ2	lights	Currently enabled output
СБР*	lights	Input Reset is enabled
БЛК*	lights	Input Lock is enabled

**NOTICE**

\* LEDs СБР and БЛК are not available on the housing Ц2.

**Table 6.3 – Buttons assignment**

Button	Operating mode of the device	Functions
	Operation	Resetting (similar to incoming "Reset" signal on the device input)
	Setup	Return previous (non-changed) value of the parameter during editing
	Operation	Change the values of setpoints
	Setup	<ul style="list-style-type: none"> <li>• Enter and exit the settings group</li> <li>• Enter the parameter editing mode and exit</li> <li>• Save the new parameter value in non-volatile memory of the device</li> </ul>
Pressing at the same time buttons  and  and holding them for 2 sec opens access to configuration setup (PC-interface parameters).		
	Operation	Select the digit to edit when changing the parameter value or entering the password (used with the buttons  and )
	Setup	
 	Operation	Change the values of setpoints
	Setup	View parameter values and edit them, enter a password



## NOTICE



\* The button  is not available on the housing 442.

### 6.3 Switch on and operation

During operation, the device counts the number of incoming pulses at its counting input, compares it with setpoint, converts this quantity into a physical value, and displays the value on the indicator. Device can operate in following modes of counting:

- count-up;
- count-down;
- command;
- individual;
- reversing;
- quadrature.

During operation the counter interprets different **types of signals**. On the device input first incoming pulse is considered as **Start** signal for counting. Counting stops when the **Stop** signal (next pulse) comes.

If there is an active "**Reset**" signal, the number of counted pulses is reset (counting continues from 0).

**Block** prevents the transmission of the counting pulses to the device input. While this signal is active, counting is blocked.



### CAUTION

The setpoint is specified with the same accuracy as for counting physical values.. The multiplier can be set from 0.00001 to 99999. The conversion of counting results (result of multiplying) will be rounded up.




Read more about each of the counting modes, see *section 7.2*.

The counter also **filters** the input signals with two filters. The **first** one filters the signal on the counting input by pulse duration (from 1 to 50,000 Hz), the **second** filters signal on the control inputs of the device (from 1 to 999999 microseconds).

## 7 Setup

### 7.1 Sequence of setup

The **Setup** mode is intended for viewing and editing the device parameters. New parameters are saved to non-volatile memory of the device.

To enter (or exit) the **Setup** mode, press and hold button  for at least 2 seconds. For access to configuration setup (parameters of connection with PC) press at the same time buttons  and  and hold them for 2 sec.

While editing, if no button is pressed within 2 min., device automatically restores previous value of the parameter and returns to parameter view mode. If within 3 minutes there are no actions in **Setup** menu, device automatically returns to **Operation**.

When device enters **Setup** for the first time, upper indicator shows *PASS*. Enter a new 4-digit password (default is 0000), save it and memorise. This password is further required for changing the device settings and for restoring factory settings (*DEFAULT*).



**NOTICE**

If you forgot your password, **Setup** mode can be entered with password **1098**. When this value is entered, password is reset to 0000. Therefore, it is not recommended to set the new user password as 1098, because in this case, each time the password is entered, its value will be reset to default.

Structure of the **device settings** menu and sequence of pressing the buttons for setup is shown in *figure 7.1* and *figure 7.2*.

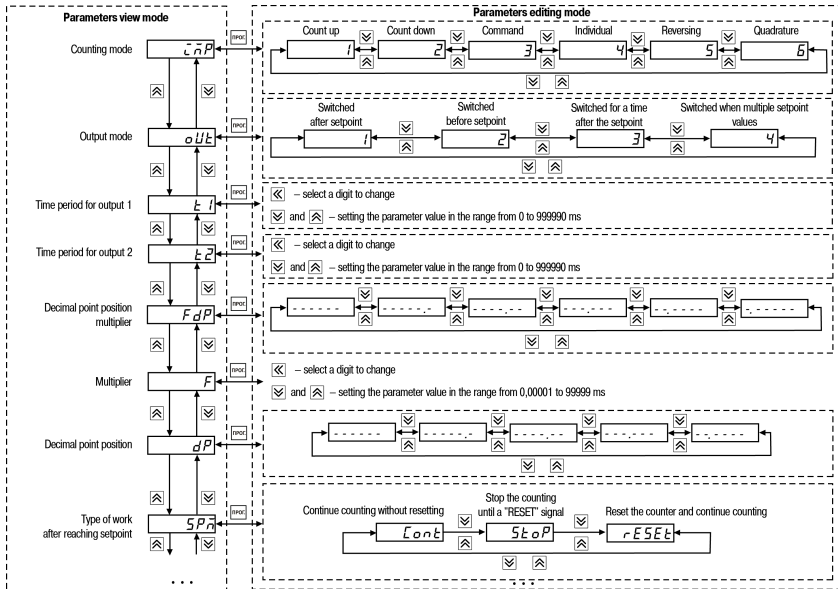


Figure 7.1 – Device settings menu (beginning)

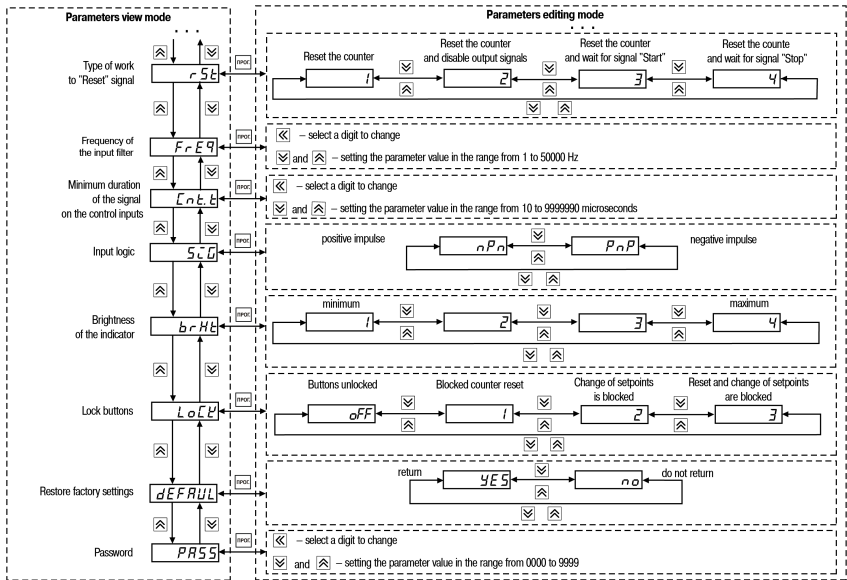


Figure 7.2 – Device settings menu (ending)

Since the  $F_{d^P}$  and  $d^P$  parameters set restrictions on each other (the number of displayed digits after the decimal point in the counting results can not be larger than the number of digits after the decimal point of the entered multiplier), editing of parameters  $F_{d^P}$ ,  $d^P$ ,  $F$  should be performed in the following sequence:

- to increase the number of displayed digits after the decimal point (decimal point offset to the left):
  - set parameter  $F_{d^P}$ ;
  - set parameter  $F$ ;
  - set parameter  $d^P$ ;
- to decrease the number of displayed digits after the decimal point (decimal point offset to the right):
  - set parameter  $d^P$ ;
  - set parameter  $F_{d^P}$ ;
  - set parameter  $F$ .

Structure of the **RS-485 configuration settings** menu and sequence of pressing the buttons for setup is shown in *Figure 7.3*.



**NOTICE**

The list of configurable parameters of the device and their possible values is shown in *Appendix A*.



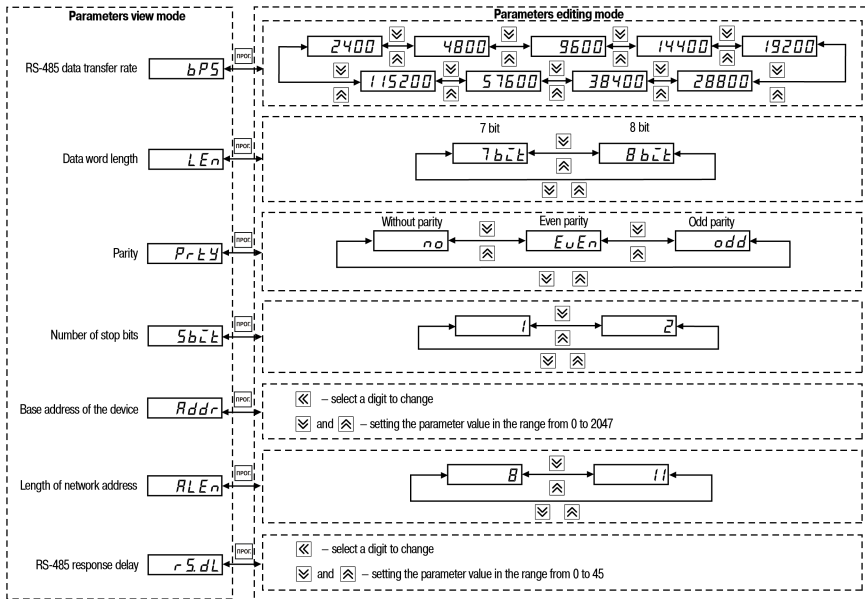


Figure 7.3 – RS-485 settings menu RS-485

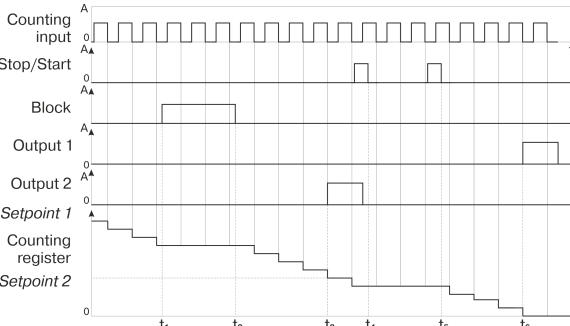
## 7.2 Setting the operating mode of the counter

Available types of counting (depending on the values of parameter  $\bar{L}nP$ ) are presented in *Table 7.1*.

**Table 7.1 – Types of counting**

Name of the mode	Input functions	Principle of operation	Illustration
Count-up ( $\bar{C}n^P = i$ )	Input 1 - count Input 2 - start/stop Input 3 - reset Input 4 - block	Counting pulses from zero upwards. When the highest setpoint is reached, the corresponding output is switched and the counter is reset	<p> <math>\{t_1-t_2\}</math> – blocking signal the counting inputs;  <math>t_3</math> – moment of switching of output 2 in case of coincidence of values of the counting register and setpoint 2;  <math>\{t_4-t_5\}</math> – stop-start signal;  <math>t_6</math> – moment of switching of output 1 in case of coincidence of values of the counting register and setpoint 1         </p>

**Table 7.1 (continued)**

Name of the mode	Input functions	Principle of operation	Illustration
Count-down ( $\bar{L}n^P = \bar{2}$ )	Input 1 - count Input 2 - start/stop Input 3 - reset Input 4 - block	Counting pulses from the highest by the module setpoint to zero (decreasing). When the zero is reached, corresponding output is switched and the setpoint register is written to the count register	 <p>The diagram shows the following signals over time <math>t</math>:</p> <ul style="list-style-type: none"> <li><b>Counting input:</b> A series of regular pulses.</li> <li><b>Stop/Start:</b> Two narrow pulses at times <math>t_4</math> and <math>t_5</math>.</li> <li><b>Block:</b> A wide pulse from <math>t_1</math> to <math>t_2</math>.</li> <li><b>Output 1:</b> A pulse at time <math>t_6</math>.</li> <li><b>Output 2:</b> A pulse at time <math>t_3</math>.</li> <li><b>Setpoint 1:</b> A staircase signal that decreases as counting pulses occur.</li> <li><b>Counting register:</b> A staircase signal that decreases as counting pulses occur.</li> <li><b>Setpoint 2:</b> A horizontal line representing a constant setpoint value.</li> </ul> <p>Key time points are marked: <math>t_1</math> (start of block), <math>t_2</math> (end of block), <math>t_3</math> (output 2 pulse), <math>t_4</math> (stop/start pulse), <math>t_5</math> (stop/start pulse), and <math>t_6</math> (output 1 pulse).</p> <p><math>\{t_1-t_2\}</math> – blocking signal on the counting inputs;  <math>t_3</math> – moment of switching of output 2 in case of coincidence of values of the counting register and setpoint 2;  <math>\{t_4-t_5\}</math> – stop-start signal;  <math>t_6</math> – moment of switching of output 1 in case of coincidence of values of the counting register and setpoint 1</p>
Command count ( $\bar{L}n^P = \bar{3}$ )	Input 1 - count Input 2 - direction of count	Two inputs are used: counting pulses are applied to the first, the status of the second determines the direction of the count. If there is a "logical 0" at the second output, the counter increases its value, if there is a "logical 1" it decreases. In this type two setpoints can be set, meanwhile:	

**Table 7.1 (continued)**

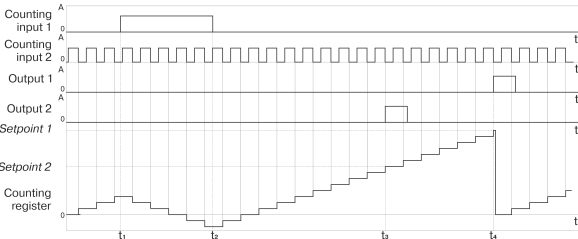
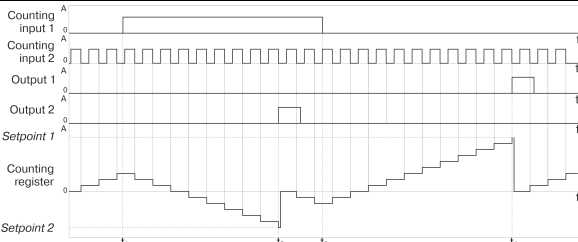

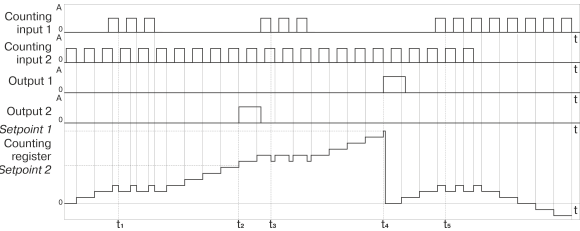
Name of the mode	Input functions	Principle of operation	Illustration
	Input 3 - reset Input 4 - block	• if the setpoints have the same sign, counter resets after reaching the setpoint, that is larger by module.	 <p> <math>\{t_1-t_2\}</math> – the decrease in the value of the counting register (impulse appears at the counting input 2);  <math>t_3</math> – moment of switching of output 2 in case of coincidence of values of the counting register and setpoint 2;  <math>t_4</math> – moment of switching of output 1 in case of coincidence of values of the counting register and setpoint 1                 </p>

Table 7.1 (continued)

Name of the mode	Input functions	Principle of operation	Illustration
		<ul style="list-style-type: none"> <li>• if the setpoints have different signs, the counter is reset after reaching each value</li> </ul>	 <p> <math>\{t_1-t_3\}</math> – the decrease in the value of the counting register (impulse appears at the counting input 2);  <math>t_2</math> – moment of switching of output 2 in case of coincidence of values of the counting register and setpoint 2;  <math>t_4</math> – moment of switching of output 1 in case of coincidence of values of the counting register and setpoint 1         </p>
	<p><b>NOTICE</b> If the setpoint is set as zero, it is considered to be disabled, and the counter does not use it.</p>		
Individual count ( $\bar{L}n^P = 4$ )	Input 1 - count 1 Input 2 - count 2	Two counting inputs are used: pulses on Input 1 increase the value of the counting register, and the pulses on Input 2 decrease it. In this case, two setpoints are used (after reaching each of them, the corresponding output switches):	

**Table 7.1 (continued)**

Name of the mode	Input functions	Principle of operation	Illustration
	Input 3 - reset Input 4 - block	<ul style="list-style-type: none"> <li>if both setpoints have the same sign, counter does not reset after reaching lesser (by module) value. Otherwise, corresponding output is switched each time counter reaches this setpoint, regardless of the direction of the count</li> </ul>	 <p> <math>t_1, t_3, t_5</math> – moments of the decrease in the value of the counting register (impulse appears at the counting input 2);  <math>t_2</math> – moment of switching of output 2 in case of coincidence of values of the counting register and setpoint 2;  <math>t_4</math> – moment of switching of output 1 in case of coincidence of values of the counting register and setpoint 1                 </p>

**Table 7.1 (continued)**

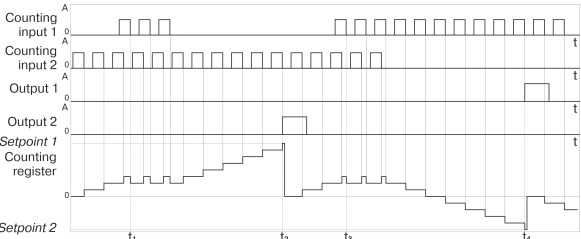
Name of the mode	Input functions	Principle of operation	Illustration
		<p>• if the setpoints have different signs (the first is greater than zero, and the second is smaller), then counter resets after reaching each setpoints</p>	 <p><math>t_1, t_3</math> – moments of the decrease in the value of the counting register (the appearance of the pulse at the counting input 2);  <math>t_2</math> – moment of switching of output 2 in case of coincidence of values of the counting register and setpoint 2;  <math>t_4</math> – moment of switching of output 1 in case of coincidence of values of the counting register and setpoint 1</p>
Reversing count ( $\bar{C}n^P = 5$ )	Input 1 - count Input 2 - change counting direction (reverse) Input 3 - reset	After the power is on, the device is in the "count-up" mode by default. For reversing count it is necessary to apply signal to input 2. Thus there are two counting inputs: pulses on Input 1, lead to an increase in the value of the counter, the counting direction is changed cyclically with each incoming pulse on Input 2. In this case, two setpoints are used (after reaching each of them, the corresponding output switches):	



Table 7.1 (continued)

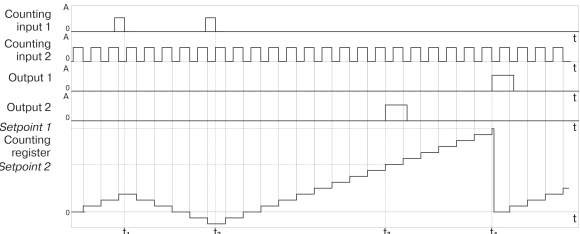
Name of the mode	Input functions	Principle of operation	Illustration
	Input 4 - block	<ul style="list-style-type: none"> <li>• if both the setpoints have the same sign</li> </ul>	 <p>The diagram illustrates the operation of a counter with two setpoints. It shows the following signals over time (t):</p> <ul style="list-style-type: none"> <li><b>Counting input 1:</b> A square wave with two positive pulses. The first pulse occurs at time <math>t_1</math> and the second at <math>t_2</math>.</li> <li><b>Counting input 2:</b> A high-frequency square wave that changes its phase (direction of counting) at <math>t_1</math> and <math>t_2</math>.</li> <li><b>Output 1:</b> A square wave that switches from low to high at time <math>t_4</math>.</li> <li><b>Output 2:</b> A square wave that switches from low to high at time <math>t_3</math>.</li> <li><b>Setpoint 1 (Counting register):</b> A staircase function that increases and then decreases, with a vertical reset at <math>t_4</math>.</li> <li><b>Setpoint 2:</b> A staircase function that increases and then decreases, with a vertical reset at <math>t_3</math>.</li> </ul> <p>Key time points are marked on the x-axis: <math>t_1</math> and <math>t_2</math> are moments of change in counting direction; <math>t_3</math> is the moment of switching output 2; <math>t_4</math> is the moment of switching output 1.</p> <p><math>t_1, t_2</math> – moments of change of the counting direction (the appearance of the pulse at the counting input 2);  <math>t_3</math> – moment of switching of output 2 in case of coincidence of values of the counting register and setpoint 2;  <math>t_4</math> – moment of switching of output 1 in case of coincidence of values of the counting register and setpoint 1</p>

Table 7.1 (continued)

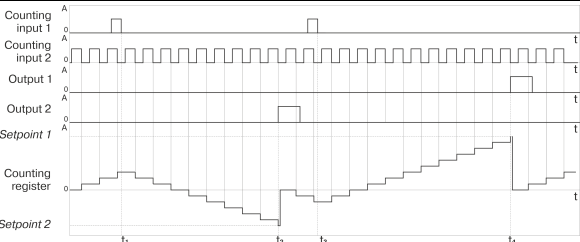
Name of the mode	Input functions	Principle of operation	Illustration
		<ul style="list-style-type: none"> <li>• if the setpoints have different signs</li> </ul>	 <p> <math>t_1, t_3</math> – moments of change of the counting direction (the appearance of the pulse at the counting input 2);  <math>t_2</math> – moment of switching of output 2 in case of coincidence of values of the counting register and setpoint 2;  <math>t_4</math> – moment of switching of output 1 in case of coincidence of values of the counting register and setpoint 1         </p>
Quadrature / operation with encoders ( $\bar{C}n^P = \bar{B}$ )	Input 1 - count 1 Input 2 - count 2 Input 3 - reset Input 4 - block	The counting direction is determined by the meanders that come on two inputs. If the first meander is ahead of the second one, the counter counts the pulses at the first input in the increase mode, and if it lags – in the decrease mode. In this case, two setpoints are used (after reaching each of them, the corresponding output switches):	

Table 7.1 (continued)

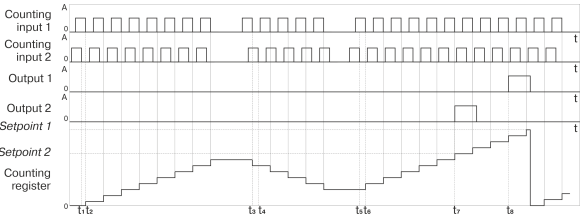
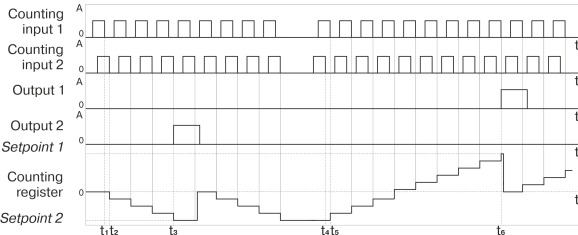

Name of the mode	Input functions	Principle of operation	Illustration
		<ul style="list-style-type: none"> <li>• if both the setpoints have the same sign</li> </ul>	 <p>The illustration is a timing diagram with the following components:</p> <ul style="list-style-type: none"> <li><b>Counting input 1:</b> A square wave with a period of 2 units. It starts at <math>t_1</math> and ends at <math>t_2</math>.</li> <li><b>Counting input 2:</b> A square wave with a period of 2 units. It starts at <math>t_3</math> and ends at <math>t_4</math>.</li> <li><b>Output 1:</b> A square wave that is high from <math>t_7</math> to <math>t_8</math>.</li> <li><b>Output 2:</b> A square wave that is high from <math>t_5</math> to <math>t_6</math>.</li> <li><b>Setpoint 1:</b> A step function that increases from 0 to 1 at <math>t_7</math>.</li> <li><b>Setpoint 2:</b> A step function that increases from 0 to 1 at <math>t_5</math>.</li> <li><b>Counting register:</b> A sawtooth wave that increases during the first input pulse and decreases during the second input pulse.</li> </ul> <p>Time markers <math>t_1, t_2, t_3, t_4, t_5, t_6, t_7, t_8</math> are indicated on the time axis.</p> <p><math>t_1, t_2, t_5, t_6</math> – meander at input 1 is ahead of the meander at the input 2, the counter counts in the mode of increasing the value of the count register;</p> <p><math>t_3, t_4</math> – the meander at input 1 lags behind the meander at input 2, the counter counts in the mode of decreasing the value of the counting register;</p> <p><math>t_7</math> – moment of switching of output 2 for the time of exceeding the value of setpoint 2 by the counting register;</p> <p><math>t_8</math> – moment of switching of output 1 for the time of exceeding the value of setpoint 1 by the counting register</p>

Table 7.1 (continued)

Name of the mode	Input functions	Principle of operation	Illustration
		<ul style="list-style-type: none"> <li>• if setpoints have different signs</li> </ul>	 <p> <math>t_1, t_2</math> – the meander at input 1 lags behind the meander at input 2, the counter counts in the mode of increasing the value of the count register;  <math>t_3</math> – moment of switching of output 2 in case of coincidence of values of the counting register and the setpoint 2;  <math>t_4, t_5</math> – the meander at input 1 is ahead of the meander at input 2, the counter counts in the mode of increasing the value of the count register;  <math>t_6</math> – moment of switching of output 1 in case of coincidence of values of the counting register and the setpoint 1         </p>
	<p><b>NOTICE</b>            After reaching the physical limit of the count (if the counter does not reset after reaching the setpoint), the device transfers the overflow result and continues the count.</p>		

## 7.3 Configuring the device from PC

Device can be configured from PC by using RS-485 and USB communication interfaces. It supports three communication protocols: OWEN, MODBUS RTU и MODBUS ASCII. Addresses, names, dimensionalities, hash-codes and other configuration parameters are given in *Appendix A*.

Functions of the software "Configurator СИ30" (file **cfgSI30.exe**), which is designed for configuring the device with PC, are described in the user manual "Pulse counter, model СИ30. Configuration" on the CD supplied. The configurator can be downloaded free from the website: [www.owen.ru](http://www.owen.ru).

Parameters for reading indications of the counter from PC are described in *Table A.2*.

## 8 Maintenance

Safety measures (see *section 3*) should be observed during the maintenance.

Maintenance of the device has to be carried out at least once in 6 months and includes the following procedures:

- checking the mounting of the device;
- checking the screw connections;
- removing dust and dirt from the terminal block of the device.

## 9 Marking

The housing of the device is marked with:

- name of the device;
- protection class of the housing according to GOST 14254;
- voltage and frequency of supply;

- power consumption;
- class of protection against electric shock according to GOST 12.2.007.0;
- sign of type approval for measuring devices;
- EAC sign;
- country of origin;
- serial number of the device and the year of manufacture.

Consumer packaging is marked with:

- name of the device;
- EAC sign;
- country of origin;
- serial number of the device and the year of manufacture.

## **10 Packaging**

Device should be packed according to GOST 23088-80 into consumer packaging, made of paperboard (according to GOST 7933-89).

Packaging of the device for mail delivery is performed according to GOST 9181-74.

## **11 Transportation and storage**

The device should be transported in closed vehicles of any kind. Packages should be fixed for transportation according to rules for corresponding type of vehicle.

Transport conditions must comply with conditions 5 in GOST 15150-69 (ambient temperature from minus 25 to +55 °C with observance of protection measures against impacts and vibrations).

Transportation should be carried out in individual packaging or in containers.

Storage conditions in containers on the warehouse of the manufacturer and consumer must correspond to conditions 1 in GOST 15150-69. The air must not contain aggressive admixtures.

The device should be stored on racks.

## 12 Scope of delivery

Item	Quantity
The device	1 piece
Passport and warranty card	1 piece
User manual	1 piece
The verification procedure (at the request of the customer)	1 piece
Fasteners	1 set
CD with the software	1 piece



### NOTICE

The manufacturer reserves the right to make additions to the contents of the device.

## 13 Warranty

The manufacturer guarantees conformity of the device to requirements of technical conditions (TY) under the conditions of operation, transportation, storage and installation.

Warranty period of operation – **24 months** from the date of sale.

In case of failure of the device during the warranty period at observance of conditions of operation, transportation, storage and installation the manufacturer undertakes to provide free repair or replacement.

Sequence of transmitting the device to service center is written in the passport and in the warranty card.




## Appendix A. Device parameters

Table A.1 – Configurable parameters

Parameter name and designation	Modbus address	Modbus function Write / Read	Hash-code	Format, data size	Range of values and indication	Factory settings
Setpoint 1 <i>U1</i>	0×000C 0×000D	0×06, 0×10 / 0×03	0×FA1E	Long (4 bytes)	from minus 99999 to 999999	999999
Setpoint 2 <i>U2</i>	0×000E 0×000F	0×06, 0×10 / 0×03	0×9707	Long (4 bytes)	from minus 99999 to 999999	0
Counting mode <i>cnp</i>	0×0008	0×06, 0×10 / 0×03	0×38D9	Word (2 bytes)	0 – Count-up (1)	Count-up
					1 – Count-down (2)	
					2 – Command (3)	
					3 – Individual (4)	
					4 – Reversing (5)	
5 – Quadrature (6)						
Output mode <i>oUt</i>	0×0009	0×06, 0×10 / 0×03	0×D11F	Word (2 bytes)	0 – Switched after setpoint (1)	Switched after setpoint
					1 – Switched before setpoint (2)	
					2 – Switched for a time after the setpoint (3)*	
					3 – Switched when multiple setpoint values (4)	

**Table A.1 (continued)**

Parameter name and designation	Modbus address	Modbus function Write / Read	Hash-code	Format, data size	Range of values and indication	Factory settings
 <b>NOTICE</b> * After reaching the setpoint the output is switched for a time period, that is specified in parameters $t_1$ and $t_2$ , the count value is reset and the counting continues from zero (parameter $SPn = rESEt$ ).						
Time period for output 1 $t_1$	0×0010 0×0011	0×06, 0×10 / 0×03	0×2E75	Unsigned long (4 bytes)	from 0 to 999990 ms	1000 ms
Time period for output 2 $t_2$	0×0012 0×0013	0×06, 0×10 / 0×03	0×436C	Unsigned long (4 bytes)	from 0 to 999990 ms	1000 ms
Decimal point position multiplier $F_{dP}$	0×0014	0×06, 0×10 / 0×03	0×6ABF	Word (2 bytes)	0 (---) 1 (---.) 2 (---.) 3 (-.-) 4 (-.-) 5 (-.-)	0
Multiplier $F$	0×0015 0×0016	0×06, 0×10 / 0×03	0×3085	Unsigned long (4 bytes)	from 0.00001 to 99999	1
Position of the decimal point $dP$	0×0007	0×06, 0×10 / 0×03	0×B3EB	Word (2 bytes)	0 (---) 1 (---.) 2 (---.)	0

**Table A.1 (continued)**

Parameter name and designation	Modbus address	Modbus function Write / Read	Hash-code	Format, data size	Range of values and indication	Factory settings
					3 (- -)	
					4 (- - -)	
Type of work after reaching setpoint $SP_n$	0×000A	0×06, 0×10 / 0×03	0×69B2	Word (2 bytes)	0 – Continue counting without resetting ( $Cont$ ) 1 – Stop the counting until a "RESET" signal ( $Stop$ ) 2 – Reset the counter and continue counting ( $Reset$ )	Continue counting without resetting
Type of work to "Reset" signal $rSt$	0×000B	0×06, 0×10 / 0×03	0×4C9A	Word (2 bytes)	0 – Reset the counter ( $0$ ) 1 – Reset the counter and disable output signals ( $1$ ) 2 – Reset the counter and wait for signal "Start" ( $2$ ) 3 – Reset the counter and wait for signal "Stop" ( $3$ )	Reset the counter

**Table A.1 (continued)**

Parameter name and designation	Modbus address	Modbus function Write / Read	Hash-code	Format, data size	Range of values and indication	Factory settings
Frequency of the input filter <i>F<sub>REQ</sub></i>	0×0017	0×06, 0×10 / 0×03	0×9FE6	Word (2 bytes)	from 1 to 50000 Hz	50000 Hz
Minimum duration of the signal on the control inputs <i>Ent.t</i>	0×0018 0×0019	0×06, 0×10 / 0×03	0×5C98	Unsigned long (4 bytes)	from 10 to 9999990 microseconds	10 microseconds
Input logic <sup>1)</sup> (type of input signal) <i>SCG</i>	0×001D	0×06, 0×10 / 0×03	0×601C	Word (2 bytes)	0 – nPn 1 – PnP	nPn
Brightness of the indicator <i>brHE</i>	0×001C	0×06, 0×10 / 0×03	0×0AE6	Word (2 bytes)	from 0 to 3 ( / – 4)	3
Lock buttons <i>LoCP</i>	0×001A	0×06, 0×10 / 0×03	0×E954	Word (2 bytes)	0 – Buttons unlocked (oFF) 1 – Blocked counter reset ( / ) 2 – Change of setpoints is blocked (z)	Buttons unlocked

**Table A.1 (continued)**

Parameter name and designation	Modbus address	Modbus function Write / Read	Hash-code	Format, data size	Range of values and indication	Factory settings
					3 – Reset and change of setpoints are blocked (3)	
Restore factory settings <i>dEFAULT</i>	–	–	–	–	<i>YES / no</i>	–
Password <i>PASS</i>	0×001E	0×06, 0×10 / 0×03	0×2728	Word (2 bytes)	from 0000 to 9999	0000
Displayed setpoint <sup>2)</sup> <i>IndP</i>	0×001B	0×06, 0×10 / 0×03	0×CAA0	Word (2 bytes)	0 – Setpoint 1	0
					1 – Setpoint 2	
Command for applying settings <sup>2)</sup> <i>APPL</i>	–	–	–	–	1 – Exit with saving	–
					2 – Exit without saving	
					3 – Return to factory settings	
<b>RS-485 settings</b>						
RS-485 data transfer rate <i>bPS</i>	0×0000	0×06, 0×10 / 0×03	0×B760	Word (2 bytes)	0 – 2400	9600
					1 – 4800	
					2 – 9600	
					3 – 14400; 4 – 19200	
					5 – 28800; 6 – 38400	
					7 – 57600; 8 – 115200	

**Table A.1 (continued)**

Parameter name and designation	Modbus address	Modbus function Write / Read	Hash-code	Format, data size	Range of values and indication	Factory settings
Data word length <i>LEN</i>	0×0001	0×06, 0×10 / 0×03	0×523F	Word (2 bytes)	0 – 7 bit ( <i>7bit</i> ) 1 – 8 bit ( <i>8bit</i> )	8 bit
Parity <i>Prty</i>	0×0002	0×06, 0×10 / 0×03	0×E8C4	Word (2 bytes)	0 – Without parity ( <i>n̄</i> ) 1 – Even parity ( <i>Even</i> ) 2 – Odd parity ( <i>odd</i> )	Without parity
Number of stop bits <i>Stbit</i>	0×0003	0×06, 0×10 / 0×03	0×B72E	Word (2 bytes)	0 – 1 stop bit 1 – 2 stop bits	1 stop bit
Base address of the device <sup>3)</sup> <i>Addr</i>	0×0005	0×06, 0×10 / 0×03	0×9F62	Word (2 bytes)	from 0 to 255 when <i>REN</i> = 8 from 0 до 2047 when <i>REN</i> = 11	16

**Table A.1 (continued)**

Parameter name and designation	Modbus address	Modbus function Write / Read	Hash-code	Format, data size	Range of values and indication	Factory settings
Length of network address <sup>2)</sup> <i>RLEn</i>	0×0004	0×06, 0×10 / 0×03	0×1ED2	Word (2 bytes)	8 bit	8 bit
					11 bit	
Response delay RS-485 <i>r5.dL</i>	0×0006	0×06, 0×10 / 0×03	0×CBF5	Word (2 bytes)	from 0 to 45	0
<p><b>Notes</b></p> <p>1) Setting of parameter <i>SL</i> works only together with DIP switch (see section 5.4).</p> <p>2) Parameters that are not displayed in the <b>Setup</b> mode of the device.</p> <p>3) In Modbus protocol address 0 is reserved for broadcast packages. In OWEN protocol address 255 is reserved for broadcast packages.</p>						

**Table A.2 – Readable parameters**

Designation and parameter name	Modbus address	Modbus function Read-only	Hash-code	Format and size of data	Note
Current value of the pulse counter <i>Ltr</i>	0×0000 0×0001	0×04	0×A158	Long (4 bytes)	–
Current counter value in physical units <i>LEU</i>	0×0002 0×0003	0×04	0×B8BC	Long (4 bytes)	–

**Table A.2 (continued)**

<b>Designation and parameter name</b>	<b>Modbus address</b>	<b>Modbus function Read-only</b>	<b>Hash-code</b>	<b>Format and size of data</b>	<b>Note</b>
Current status of the "Start/stop" <i>StSt</i>	0×0004	0×04	0×6577	–	0 – start; 1 – stop
Current mode (count, setup) <i>CUr</i>	0×0005	0×04	0×CC41	Word (2 bytes)	0 – count (password not required); 1 – setup from the device's buttons; 2 – setup from the PC; 3 – count (requires password)
Network error code on last access to the device <i>nErr</i>	0×0006	0×04	0×0233	Word (2 bytes)	From 0 to 255. After turning on the device – 0
Name of the device <i>dEu</i>	0×0007 0×0008	0×04	0×D681	ASCII string (4 bytes)	–
Software version <i>uEr</i>	0×0009 0×000A	0×04	0×2D5B	ASCII string (4 bytes)	X.YY, where X – number of version, YY – number of subversion



**Table A.3 – Bit parameters**

Designation and name of parameter	Modbus address	Modbus function write / read	Hash-code	Format and size of data	Note
<b>Digital inputs</b>					
Current status of the "Reset" input <i>r5t̄</i>	0×0000	– / 0×02	0×C010	Byte (1 byte) 0 / 1	–
Current status of the "Block" input <i>L0c̄</i>	0×0001	– / 0×02	0×93EC	Byte (1 byte) 0 / 1	–
<b>Digital outputs</b>					
Status of output 1 <i>ō5t̄1</i>	0×0000	– / 0×01	0×6FFD	Byte (1 byte) 0 / 1	–
Status of output 2 <i>ō5t̄2</i>	0×0001	– / 0×01	0×52A1	Byte (1 byte) 0 / 1	–
Reset of counter <i>r5t̄</i>	0×0002	0×05, 0×0F / 0×01	0×DF1F	Byte (1 byte) 0 / 1	0 – no action; 1 – reset

**Table A.3 (continued)**

<b>Designation and name of parameter</b>	<b>Modbus address</b>	<b>Modbus function write / read</b>	<b>Hash-code</b>	<b>Format and size of data</b>	<b>Note</b>
Enable/disable the program control mode counter START/ STOP <i>on/off</i>	0×0003	0×05 / –	–	–	0 – OFF (0x0000); 1 – ON (0xFF00)
Command to set the program control mode counter START/ STOP <i>PSLSt</i>	0×0004	0×05 / –	–	–	0 – STOP (0x0000); 1 – START (0xFF00)



Head office:

111024, Moscow, 2nd Entuziastov street, 5, building 5

Tel.: (495) 641-11-56

Fax: (495) 728-41-45

[www.owen.ru](http://www.owen.ru)

Sales department: [sales@owen.ru](mailto:sales@owen.ru)

Technical support: [support@owen.ru](mailto:support@owen.ru)

1-EN-100731-1.2